

December 2019



Newsletter of the County of Orange Radio Amateur Civil Emergency Service

Inside this issue:

Captain's Corner	1
OCRACES Dinner	3
3.3-3.5 GHz Band	3
Tri-Band DMR/FM	4
EOC Training	4
Cooperative T-Hunt	5
EmComm Course	5
RACES/MOU News	6
Events Calendar	7
OCRACES Members	8

Captain's Corner

by RACES Captain Ken Bourne, W6HK, Chief Radio Officer

Controlling Mobile DC Power

In this article I will share some of my mobile radio experiences, in hopes that you may benefit from my ideas.

I installed my first amateur-radio mobile station in 1956, when, as a teenager, I mounted a Gonset Super-6 converter in my dad's new 1956 Buick, along with a 10-meter AM transmitter that I built from a *QST* article, using an Army surplus PE-103 dynamotor for power. My dad even permitted holes for a body mount with a 96-inch whip antenna on his new car. (What a dad!) I immediately became active on 10-meter fox hunts!

Mobile installations have become somewhat simpler. We no longer have to dig into car radios to find high voltage for a tube-type converter, and we no longer need to install dynamotors or vibrator power supplies for mobile transmitters. However, we need to avoid causing problems to automobile computers and other sensitive circuits when installing mobile ham radios. We also need to protect our mobile radios from voltage spikes or drops.

Several years ago, I acquired a Kenwood TM-742A tri-band mobile transceiver (10 meters, 2 meters, and 70 centimeters) and began planning its installation in my Ford Explorer. I purchased a plastic mobile mounting console with a nice built-in speaker from Radio Shack. The radio had three audio outputs, one for each band, so I mounted two more speakers (Motorola) on the sides of the console. Some fellow hams mentioned to me that their mobile radios developed problems after starting their engines with the radios turned on at the time, perhaps caused by voltage spikes when starting, or by voltage drops. I also wanted my radio to turn off automati-



Gonset Super 6 converter allowed an automobile's broadcast radio to receive AM signals on the 80 through 10 meter ham bands.

cally when I turned off the ignition (to avoid draining the car battery if I accidentally left the radio on), and to turn on automatically when I started the car. Most commercial land mobile radios (Motorola, etc.) had an ignition-sensing circuit to enable automatic turn-on/turn-off, but ham transceivers typically did not have that feature. Therefore, I found a terminal under my dash that became "hot" when the ignition was turned on. I ran a lead from that terminal to my Radio Shack console. In that console I installed two small single-pole/single-throw switches and two 12-V/30-A relays. One switch, which I normally left in the "on" position, routed the ignition sense lead to the relay coil. The relay then passed battery voltage to the radio. The other switch, which I normally left in the "off" position, routed battery voltage to the other relay coil (to avoid switching high current with the small switch). When turned "on," battery voltage would then pass to the radio, even when the ignition was off, allowing me to operate the radio when the car was off. (I'm surprised no one sells a little box

OCRACES Holiday Dinner

Monday,
December 2, 2019,
at 1830 Hours

Rodrigo's
Mexican Grill

1230 E. Katella Ave.,
Orange



Orange County Sheriff's Department
Communications & Technology Division

Captain's Corner *Continued from page 1*

with two switches and two relays, with a terminal strip and Powerpole connectors for battery and ignition voltage, for similar mobile installations.)

After acquiring a new Ford Crown Victoria, I had the dealer run an ignition sense wire to a convenient spot below the dash, where I was going to mount control heads for my Motorola VHF and UHF radios. Scott Byington, KC6MMF, fabricated a beautiful console for those control heads and helped me run control cables from the radios in the trunk and power cables from the battery under the hood. He also helped with installing the 2-m and 70-cm quarter-wave antennas on the trunk. On the side of the console I mounted a single-pole/double-throw/center-off switch. In the down (normal) position, the ignition sense wire is connected to the ignition-sensing terminal of the control heads, allowing the radios to turn on only when the ignition is on. In the up position, the battery voltage is connected to the ignition-sensing terminals, allowing the radios to operate even when the ignition is off. In the center position, no voltage is applied to the ignition-sensing terminals, and the radios are off. (I switch to that position when I have my car serviced or valet-parked, to prevent unauthorized transmissions.)

I no longer have a need to be a "Motorola snob," so I'll eventually replace my Motorola radios with a transceiver intended for amateur use, which can be quickly front-panel programmed to any amateur VHF or UHF frequency (unlike a Motorola radio). Unfortunately, my new radio probably won't have an ignition-sensing terminal. Therefore, I might go back to my original scheme of two switches and two relays, using an ignition sense wire to control battery voltage to my radio.

An easier method (with pros and cons compared to my two-switches/two-relays system) might be to connect an MFJ-4402 mobile transceiver protector. It has a delay timer

circuit controlled from the ignition sense wire to prevent your radio from turning on until your vehicle has started and the voltage has reached normal levels. It disconnects the power until the time-out period is completed. This will also prevent the radio from draining the vehicle's battery if it is left on. (Some radios have circuits that remain active even when the radio is turned off, resulting in some current drain.) The MFJ-4402 has a circuit to cut the radio off if the voltage gets too low for proper operation, to prevent such problems as memory loss or corruption, distorted audio, etc.

The MFJ-4402 also has an internal transient surge protector circuit, to prevent problems caused by electrical surges. A faulty regulator in the alternator could cause excessive voltages. Sudden changes in loads could cause momentary overshoots of the alternator voltage. Jump-starting off other cars could cause voltage spikes (especially off a truck with a 24-volt electrical system!). The protector will also blow its internal 30-A fuse in the case of over-current or if the voltage polarity is accidentally reversed on the battery leads.

Connections between the MFJ-4402 and the vehicle and the radio are made through Anderson Powerpole connectors for the high-current lines and a quick-disconnect connector for the ignition sense line.



MFJ-4402 mobile transceiver protector comes in a 2½ × 4 × 1½ inch case.

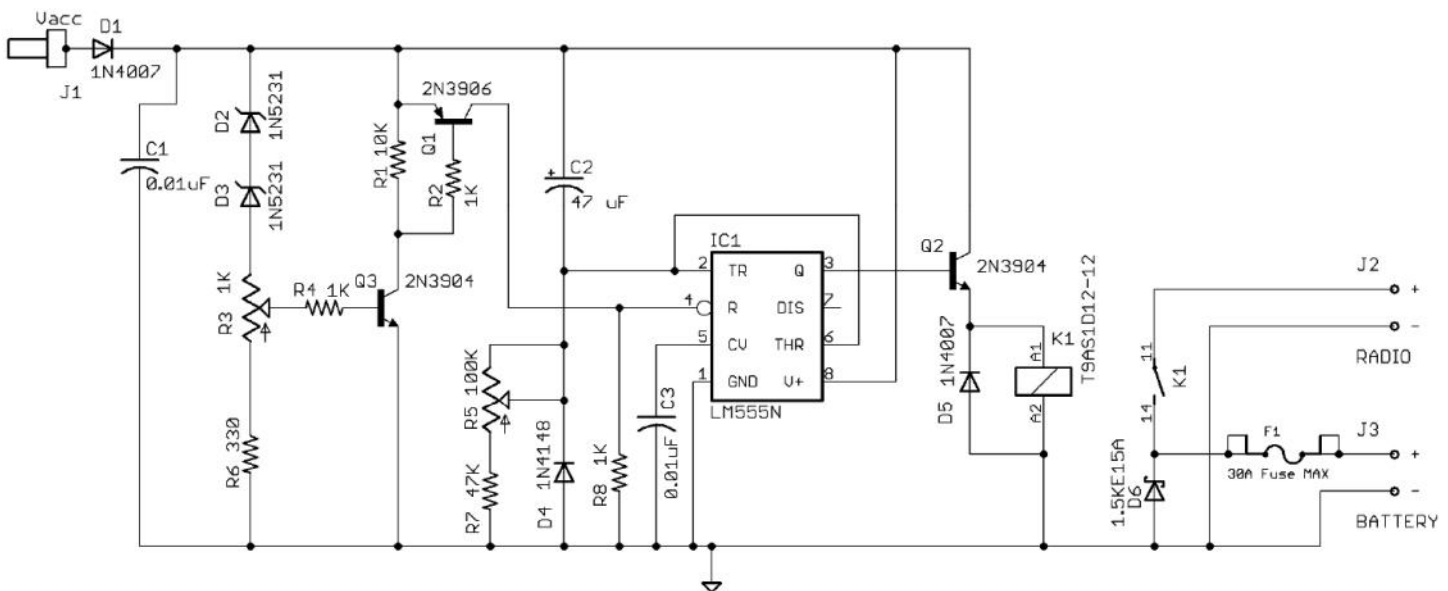

Schematic of MFJ-4402 mobile transceiver protector.

OCRACES Holiday Dinner: December 2nd

OCRACES members and active applicants and their families will gather for their annual holiday dinner on Monday, December 2, 2019, at 6:30 PM, at Rodrigo's Mexican Grill, 1230 E. Katella Avenue, in Orange. The cost is \$22 per person and includes a selection of five pre-selected menu items and non-alcoholic drink. That selection is made that night, and no pre-order is necessary. RSVP to OCSO Emergency Communications Coordinator Peter Jimenez, KI6UTE, at PJimenez@ocsd.org. There will be no regular OCRACES meeting or net on December 2nd.

The next regular OCRACES meeting will be on Monday, January 6, 2020, at 7:30 PM, at OCSO Communications & Technology Division, 840 N. Eckhoff Street, Suite 104, in Orange.

ARRL to Oppose 3.3-3.5 GHz Band Elimination

The following information was posted on the ARRL website on November 25, 2019.

At its December 12th open meeting, the FCC will consider adopting a *Notice of Proposed Rulemaking (NPRM)* that proposes to remove the amateur radio 9-centimeter allocation at 3.3-3.5 GHz. ARRL plans to comment in opposition to the proposed action. According to an FCC "Fact Sheet," the proceeding WT Docket 19-348, "Facilitating Shared Use in the 3.1-3.55 GHz Band," is a follow-on from the MOBILE NOW Act, approved by the 115th Congress, which requires the FCC and the US Department of Commerce to make available new spectrum for mobile and fixed wireless broadband use. It also requires the FCC to work with the National Telecommunications and Information Administration (NTIA) to evaluate whether commercial wireless services and federal incumbents could share spectrum between 3.1 and 3.55 GHz. NTIA manages spectrum allocated to federal government users.

"This *Notice of Proposed Rulemaking* would propose to remove the existing non-federal allocations in the 3.3 – 3.55 GHz band as a step towards potential future shared use between federal incumbents and commercial users," the FCC Fact Sheet explains. "By taking the initial step needed to clear the band of allocations for non-federal incumbents, the Commission furthers its continued efforts to make more mid-band spectrum potentially available to support next generation wireless networks—consistent with the mandate of the MOBILE NOW [Making Opportunities for Broadband Investment and Limiting Excessive and Needless Obstacles to Wireless] Act."

The *NPRM* proposes to clear the 3.3-3.55 GHz band of existing non-federal users by removing *non-federal secondary radiolocation and amateur allocations* [emphasis added] in the 3.3-3.55 GHz band and to relocate incumbent non-federal users out of the band. The FCC would seek comment on relocation options and "transition mechanisms" for incumbent non-federal users, either to the 3.1-3.3 GHz band or to other frequencies, and on how to ensure that non-federal secondary operations in the 3.1-3.3 GHz band will continue to protect federal radar systems.

Regarding the Amateur and Amateur-Satellite Service allocations, the FCC *NPRM* asks whether existing amateur spectrum in other bands might support operations currently conducted in the 3.3-3.5 GHz band (including weak-signal activity at 3.456 GHz). The 3.40-3.41 GHz segment is designated for amateur satellite communication. "We seek comment on the extent to which the band is used for this purpose, whether existing satellites can operate on other amateur satellite bands, and on an appropriate timeframe for terminating these operations in this band," the FCC *NPRM* says.

Also at its December 12th meeting, the FCC will consider another *NPRM* in WT Docket 19-138 that would "take a fresh and comprehensive look" at the rules for the 5.9 GHz band and propose, among other things, to make the lower 45 MHz of the band available for unlicensed operations and to permit "Cellular Vehicle-to-Everything" (C-V2X) operations in the upper 20 MHz of the band. The FCC is not proposing to delete or otherwise amend the amateur allocation, and it would continue as a secondary allocation, but the primary allocation for 5.850-5.925 GHz would change.

The amateur radio 5-centimeter allocation is 5650.0-5925.0 MHz, and the *NPRM*, if approved, would address the top 75 MHz of that amateur secondary band. While no changes are proposed to the amateur allocation, anticipated more intensive use by primary users could restrict secondary amateur use.

The band 5.850-5.925 GHz has been reserved for use by dedicated short-range communications (DSRC), a service in the intelligent transportation system (ITS) designed to enable vehicle-related communications, the FCC said in a Fact Sheet in WT Docket 19-138. "The Commission initiates this *Notice of Proposed Rulemaking* to take a fresh and comprehensive look at the 5.9 GHz band rules and propose appropriate changes to ensure the spectrum supports its highest and best use." ARRL also will file comments opposing any changes affecting the 5-centimeter amateur allocation.

Both draft FCC proposals are subject to change prior to a vote at the December 12 FCC meeting, and there will be opportunity to file comments and reply comments on the final proposals after they are released.

AnyTone Offers Tri-Band Mobile DMR/FM Rig

The new AnyTone AT-D578UVIII tri-band DMR and analog radio covers the 2-meter and 70-centimeter bands and also the 1¼-meter (222 MHz) band. It features a 1.77-inch color TFT display, Bluetooth, GPS, and DMR repeater roaming. Output power is 50 W (2 m), 10 W (1¼ m), and 45 W (70 cm). Full duplex receive (V+V, U+U, and V+U) on two bands is offered, with two volume controls. Single and dual speaker outputs are provided. The receiver automatically selects to incoming digital or analog signals.

On DMR, the AT-D578UVIII offers 4,000 channels, 10,000 talk groups, and 200,000 digital contacts. The 250 zones are selectable from the microphone keypad. The radio is DMR-APRS and analog-APRS capable. Background display and font colors are user-changeable. Digital monitor allows monitoring of all talk groups in one or two timeslots.

At least a couple of dealers have announced the price to be \$399.99. Delivery is predicted for December 2019.



AnyTone AT-D578UVIII tri-band DMR/analog FM mobile transceiver covers 2 m, 1¼ m, and 70 cm.

OCSD/EMD Offers Training Classes at EOC

OCSD Emergency Management Division (EMD) reminds us that our County identification designates us as Disaster Service Workers (DSWs). (The California Government Code, Section 3101, says the term, “disaster service worker” includes all public employees and all volunteers in any disaster council or emergency organization accredited by the Office of Emergency Services. We as volunteers needed to sign the oath of affirmation set forth in Section 3 of Article XX of the Constitution of California. DSWs are “subject to such disaster service activities as may be assigned to them by their superiors or by law.”) EMD says as Disaster Service Workers we may be called upon to participate in exercises for preparedness or activation by the County Emergency Operations Center (EOC) in the event of a disaster.

Training opportunities are available to acquaint you with the EOC, the California State mandated Standardized Emergency Management System (SEMS), as well as your role during emergencies and exercises.

EMD has released a training schedule of offered courses. Space permitting, we will list and describe the courses for the next two months in each issue of *NetControl*. Please contact EMD to register for training classes by e-mailing Michelle Baldwin at mbaldwin@ocsd.org. Confirmation for training and a map to the EOC will be sent to you by e-mail upon receipt of your approved registration. If you have not received confirmation within one week of the training date, please e-mail Michelle.

The courses offered for December 2019 at the Orange County EOC include:

- **Care and Shelter Branch Training**—Operations Center; Wednesday, December 3, 2019; 9:30 AM to 12:00 PM. This course is designed for individuals who may staff a position within the Care and Shelter Branch during an exercise or activation of the EOC or those interested in the EOC Care and Shelter Branch. Training will include an overview of the positions within the Care and Shelter Branch and their responsibilities. The training will include hands-on practice on position-specific roles and responsibilities.
- **AlertOC Training**—Support Center; Tuesday, December 10, 2019; 10:00 AM to 12:00 PM. AlertOC training is a 2-hour session designed to go over the processes and procedures to send a notification using the Everbridge system. This course addresses the main features of Mass Notification, which can also apply to other types of notifications using the Everbridge suite. Enrollment is open to all County employees and Operational Area Partners.
- **WebEOC 8.0/JIMS 8.0**—Support Center; Wednesday, December 18, 2019; 10:00 AM to 12:00 PM. WebEOC Orientation is a 2-hour class on the WebEOC Incident Management System used in EOCs. The WebEOC system has been completely redesigned and this course will demonstrate how to use the new WebEOC and JIMS 8.0 version. The class is a hands-on tutorial including login procedures, Activity logs, and the Jurisdictional Information Management System. Enrollment is open to all County employees and Operational Area Partners.

The courses offered for January 2020 at the Orange County EOC include:

- **WebEOC 8.0/JIMS 8.0**—Support Center; Thursday, January 16, 2020; 1:30 PM to 3:30 PM.
- **AlertOC Training**—Support Center; Thursday, January 23, 2020; 1:30 PM to 3:30 PM.

KM6RSY Hides in Los Alamitos

Art Remnet, KM6RSY, was the fox on the monthly cooperative T-hunt on Monday, November 18, 2019. He hid the fox box in the Federal SW Regional Lab Park & Ride parking lot on the west side of the California Department of Fish and Wildlife, just north of Lampson Avenue, directly south of the Joint Forces Training Base in Los Alamitos.

Ken Bourne, W6HK, and Roger Kepner, W6SQQ, were the first team to find the fox. Next was Ron Allerdice, WA6CYY. Having fun on their first T-hunt were Mark and Julie Warrick, KM6ZPO and KN6AOC, who came in third. Also hunting were Tim Goepfing, N6GP, and Jim Schultz, AF6N, who were frustrated with their tape-measure beam bearings.

The next hunt will be on Monday, December 16, 2019, immediately following the OCRACES 2-meter net (approximately 7:20 PM). The fox will hide on paved, publicly accessible property in a city or sector of Orange County to be announced a few days before the hunt. He will transmit tones on the input (146.295 MHz) of the 146.895 MHz repeater. Hunters will compare bearings via the 448.320 MHz repeater and are encouraged to beacon their positions via APRS while hunting. We are looking for a volunteer to be the fox.

The cooperative T-hunts are usually held on the third Monday of each month (except in October). The hunts are not official RACES events, so DSW (Disaster Service Worker) coverage does not apply. Please drive carefully!

To keep our cooperative T-hunts active, we need to have more participants. RACES members are urged to equip themselves with direction-finding equipment and be ready to find sources of interference to RACES repeaters and to VHF public-safety communications. These hunts provide excellent practice in working together to find such interference—plus they are great fun!

An easy-to-build tape-measure yagi for T-hunting is described at http://theleggios.net/wb2hol/projects/rdff_tape_bm.htm. Fox-hunt loops and beams are available from Arrow Antenna and HRO, including the Arrow Model FHL-VHF fox-hunt loop (covers 1 MHz to 600 MHz) and the Arrow Model 146-3 three-element portable hand-held yagi. The Arrow OFHA 4-MHz offset attenuator can be useful when close to the fox, to prevent receiver overload. For on-foot hunting, the BC-146.565 three-element, hand-held, foldup, yagi antenna is available from Bob Miller Enterprises (<http://www.rdfantennas.com>), along with the VK3YNG MK4 sniffer. An all-mode transceiver is quite useful, allowing hunters to switch to the SSB or CW mode for detecting extremely weak signals, or to switch in a built-in attenuator, reduce RF gain, or tune slightly off frequency when dealing with extremely strong signals. Some hunters use the DF2020T radio direction finder kit, which is a Doppler system available from Global TSCM Group, Inc. (<http://www.kn2c.us>). A very similar system is the MFJ-5005 Doppler direction finder. Useful apps are available for iPhones and Android phones. One such app is FoxHunt Pro, available for \$1.99 for iPhones. For some excellent information on T-hunting, see <http://www.homingin.com>.



At the fox's den are (left to right) Ron Allerdice, WA6CYY, Roger Kepner, W6SQQ, Art Remnet, KM6RSY (the fox), and Mark and Julie Warrick, KM6ZPO and KN6AOC.

ARRL Self-Guided Communications Course

ARRL's EC-001-S online "Introduction to Emergency Communication" course is now available to students in an on-demand format, allowing students to register for the course and begin work at any time. This course is designed to provide basic knowledge and tools for any emergency communications volunteer.

In response to the great course demand and to expand access to EC-001, ARRL developed a self-guided version of the course, EC-001-S, which launched in June 2019. This version of the course is designed for those who prefer to work independently and who do not need guidance from an online mentor. EC-001-S was previously offered only during specific sessions along with the traditional mentored version. The course opened for general enrollment on November 6th.

Visit the ARRL Online Course Registration page at <http://www.arrl.org/online-course-registration> for more information and to register.

RACES/MOU News from Around the County

"RACES/MOU News" provides an opportunity to share information from all City & County RACES/ACS units and MOU organizations and supportive amateur radio clubs in Orange County.

Please send your news to NetControl Editor Ken Bourne, W6HK, at: kbourne.ocsd@earthlink.net

Orange County Hospital Emergency Amateur Radio Team (OCHEART)

OCHEART Volunteer Recruitment Appeal

*By David Gorin, KB6BXD
OCHEART Emergency Coordinator*

It is often said that "Ham Radio Saves Lives." It would be more accurate to say "Amateur Radio Operators who are properly equipped and trained can save lives." Ham radio operators have a unique opportunity to support perhaps the most vital resource in any community: a hospital or other medical facility.

Here is the problem: All the sophisticated communications systems employed in the healthcare industry need backup. Imagine a disaster scenario where landline service, cellular service, Internet, power grid, and/or satellite phones are overloaded or defunct.

The one communications system that can still function is amateur radio. Your amateur radio skills and equipment can fill the critical gaps that history tells us will inevitably exist in a widespread emergency.

A new ARES unit known as Orange County Hospital Emergency Radio Team, or OCHEART, has been formed to establish a backup communications system for critical Orange County medical facilities.

Besides the requirement for an Amateur Radio License, OCHEART communicators are expected to complete certain FEMA and ARRL courses, demonstrate understanding of the privacy and security provisions of the Health Insurance Portability and Accountability Act (HIPAA), learn to operate appropriately in the hospital environment, and maintain portable equipment for "Every Day Carry."

Yes, you can do it. With a minimal investment in equipment and proper training and practice you can be a critical part of protecting the lives of those in need of medical assistance during a major incident or countywide disaster.

Learn what you need to have, know, and do to be a Hospital Communicator with OCHEART. Contact KB6BXD@SOARA.org for more information.

FREQUENTLY ASKED QUESTIONS

- Q: What if I am currently in a RACES group?
- A: The ARRL recommends dual membership in RACES and ARES.
- Q: What if the leadership in my RACES group expresses concern about possible conflict arising from dual membership in RACES

and OCHEART?

- A: You can assure them that there is no conflict. There may be occasions when OCHEART has been activated before any RACES activation. In such cases, a communicator with dual membership will come under the jurisdiction of a government's Emergency Management Incident Commander once RACES is activated, who may direct that RACES/OCHEART hospital communicators remain at a medical facility or be deployed elsewhere in a RACES-specific role.

Huntington Beach RACES

One of the days of the Huntington Beach Airshow was October 5, 2019, the same day as the City/County RACES & MOU drill. OCRA-CES will try to schedule future drills to avoid conflict with Huntington Beach and other city RACES events, to allow assistance to city RACES units during major events.

Accordingly, HBRACES Chief Radio Officer Jim Hansen, KG6ZDP, has revealed dates of some future events, to enable us to begin planning our assistance to them. Upcoming HBRACES 2020 activities include: the Marathon (February 2), Baker to Vegas (April 4-5), July 4th Parade, 2020 Airshow (no confirmed date), and probably others to be identified.

HBRACES' sponsor is the HB Fire Department. Should their 800-MHz radios and Metro Net go down, HBRACES does a "shadow drill," where they assign members to each piece of fire equipment with their HT radios and antennas. There are many variables in assigning a date and they attempt to do this far enough in advance so dates are clear. The date for 2020 is May 2nd.

Outdoor Adventure USA

Dave Kupfer, K6DTK, reports that his group, Outdoor Adventure USA, has been conducting a net for the past 11 years on various outdoor and ham related topics. They want to do a net on the various ham radio emergency organizations, including RACES, and are looking for RACES members who may be able to help as speakers for their net.

The group uses the Keller Peak 2-meter repeater, which serves a large part of Southern California. They are also equipped with IRLP, which enables anyone to connect, no matter where they are located. Anyone interested in being a net speaker should contact Dave at k6dtk@oausa.net. The Outdoor Adventure USA website URL is <http://www.oausa.net/>.

December 2019

Upcoming Events:

- **December 2:** OCRACES Holiday Dinner, 1830 hours, Rodrigo's Mexican Grill, 1230 E. Katella Avenue, Orange; no net
- **December 16:** Cooperative T-Hunt, 1920 hours, input of OCRACES 2-meter repeater
- **December 25:** Merry Christmas!
- **January 1:** Happy New Year!

Sun	Mon	Tue	Wed	Thu	Fri	Sat
1	2 OCRACES Holiday Dinner	3	4	5	6	7 Weekly 60 m ACS Net
8	9 Weekly 2 m ACS Net	10	11	12	13	14 Weekly 60 m ACS Net
15	16 Weekly 2 m ACS Net & Cooperative T-Hunt	17	18	19	20	21 Weekly 60 m ACS Net
22	23 ACS Net on Five Bands & Cal OES Nets	24 Christmas Eve	25 Christmas Day	26	27	28 Weekly 60 m ACS Net
29	30 Weekly 2 m ACS Net	31 New Year's Eve				



www.ocraces.org



Mission Statement

County of Orange RACES has made a commitment to provide all Public Safety departments in Orange County with the most efficient response possible to supplement emergency/disaster and routine Public Safety communications events and activities. We will provide the highest level of service using Amateur and Public Safety radio resources coupled with technology, teamwork, safety, and excellence. We will do so in an efficient, professional, and courteous manner, accepting accountability for all actions. We dedicate ourselves to working in partnership with the Public Safety community to professionally excel in the ability to provide emergency communications resources and services.

County of Orange RACES Frequencies

- 60 m: 5371.5 kHz USB (dial) (Channel 4) (OC ACS Net—Saturdays, 1000 hours)
 - 40 m: 7250 kHz LSB
 - 10 m: 29.640 MHz output, 29.540 MHz input, 107.2 Hz PL
 - 6 m: 52.620 MHz output, 52.120 MHz input, 103.5 Hz PL
 - 2 m: 146.895 MHz output, 146.295 MHz input, 136.5 Hz PL*
 - 2 m: 146.595 MHz simplex
 - 1.25 m: 223.760 MHz output, 222.160 MHz input, 110.9 Hz PL
 - 70 cm: 446.000 MHz simplex
 - 70 cm: 448.320 MHz output, 443.320 MHz input, 141.3 Hz PL (private)
 - 70 cm: 449.100 MHz output, 444.100 MHz input, 110.9 Hz PL (private)
 - 70 cm: 449.180 MHz output, 444.180 MHz input, 107.2 Hz PL (private)
 - 70 cm: 449.680 MHz output, 444.680 MHz input, 131.8 Hz PL (private)
 - 23 cm: 1287.650 MHz, 1287.675 MHz, 1287.700 MHz, 1287.725 MHz, 1287.750 MHz, and 1287.775 MHz outputs, -12 MHz inputs, 88.5 Hz PL
- *Primary Net—Mondays, 1900 hours

OCSD Emerg. Comm's Coordinator
Pete Jimenez, KI6UTE, 714-704-8080

Radio Officer (Lieutenant)
Scott Byington, KC6MMF

OCSD Sr. Telecommunications Engr.
Erik Schull, KE6BVI, 714-704-7937

Assistant Radio Officers (Sergeants)
Jack Barth, AB6VC
Ernest Fierheller, KG6LXT
Bob McFadden, KK6CUS
Tom Tracey, KC6FIC

Chief Radio Officer (Captain)
Ken Bourne, W6HK, 714-997-0073

County of Orange RACES

OCSD Communications & Technology Division
840 N. Eckhoff Street, Suite 104, Orange, CA 92868-1021
Telephone: 714-704-8080 or 714-704-7937 • Fax: 714-704-7902
E-mail: pjimenez@ocsd.org or eschull@ocsd.org

County of Orange RACES

OCSD/Communications & Technology
840 N. Eckhoff Street, Suite 104
Orange, CA 92868-1021

Telephone – 714-704-8080 or 714-704-7937
Fax – 714-704-7902
E-mail – pjimenez@ocsd.org or eschull@ocsd.org

Visit Our Web Site
<https://ocraces.org>
It's Where It's @!

Questions or Comments?
Contact *NetControl* Editor Ken Bourne, W6HK
kbourne.ocsd@earthlink.net



**“W6ACS ...
Serving
Orange County”**

Meet Your County of Orange RACES Members!

Officers →



Ken Bourne
W6HK

Scott Byington
KC6MMF

Jack Barth
AB6VC

Ernest Fierheller
KG6LXT

Bob McFadden
KK6CUS

Tom Tracey
KC6FIC



Randy Benicky
N6PRL

Ray Grimes
N8RG

Lee Kaser
KK6VIV

Walter Kroy
KC6HAM

Martin La Rocque
N6NTH

Don Mikami
N6ELD



Harvey Packard
KM6BV

Tony Scalpi
N2VAJ

Joe Selikov
KB6EID

Robert Stoffel
KD6DAQ

Ken Tucker
WF6F

Tom Wright
KJ6SPE

**OCSD
RACES** →
Coordinators



Peter Jimenez
KI6UTE



Erik Schull
KE6BVI